

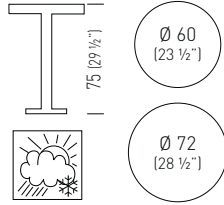

TKITT.BG3K

H75 Table with technopolymer top, BG3K 3-spur metal-technopolymer co-injected table base, Ø 80mm anodized aluminum column.

Tavolo con piano in tecnopolimero H75, basamento BG3K a tre razze in metallo sovrastampato con tecnopolimero, colonna in alluminio anodizzato Ø 80mm.



■ TKITT04._/BG3K 0.13m³ / 13.8kg / 1pcs
 ■ TKITT04._/BG3K.10 0.13m³ / 13.8kg / 1pcs

■ TKITT03._/BG3K 0.15m³ / 14.5kg / 1pcs
 ■ TKITT03._/BG3K.10 0.15m³ / 14.5kg / 1pcs

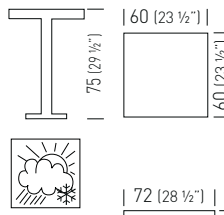

■ TKITT20._/BG3K 0.13m³ / 14.6kg / 1pcs
 ■ TKITT20._/BG3K.10 0.13m³ / 14.6kg / 1pcs

■ TKITT06._/BG3K 0.15m³ / 15.8kg / 1pcs
 ■ TKITT06._/BG3K.10 0.15m³ / 15.8kg / 1pcs

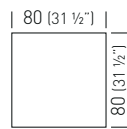

■ TKITT23._/BG3K 0.16m³ / 18.4kg / 1pcs
 ■ TKITT23._/BG3K.10 0.16m³ / 18.4kg / 1pcs

Top Color / Colore Piano

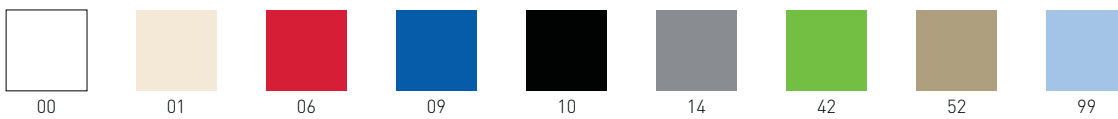

TKITT.BG3L

H75 Table with technopolymer top, BG3L 3-spur metal-technopolymer co-injected table base, Ø 80mm anodized aluminum column.

Tavolo con piano in tecnopolimero H75, basamento BG3L a tre razze in metallo sovrastampato con tecnopolimero, colonna in alluminio anodizzato Ø 80mm.

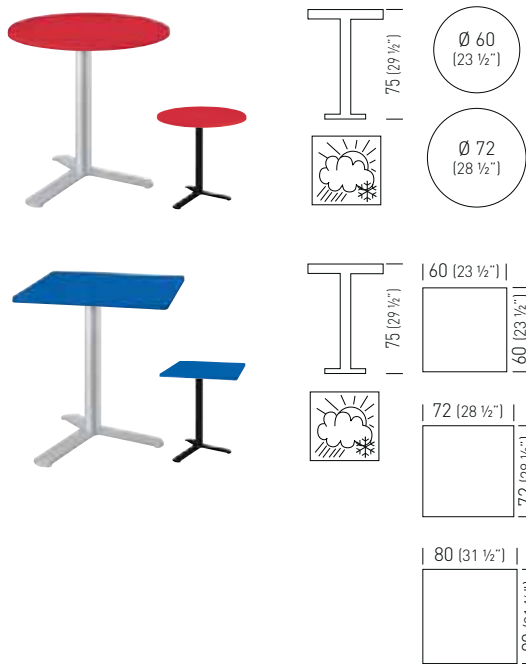

■ TKITT04._/BG3L		0.14m³ / 15kg / 1pcs
■ TKITT04._/BG3L.10		0.14m³ / 15kg / 1pcs
■ TKITT03._/BG3L		0.16m³ / 15.7kg / 1pcs
■ TKITT03._/BG3L.10		0.16m³ / 15.7kg / 1pcs
■ TKITT20._/BG3L		0.14m³ / 15.8kg / 1pcs
■ TKITT20._/BG3L.10		0.14m³ / 15.8kg / 1pcs
■ TKITT06._/BG3L		0.16m³ / 17kg / 1pcs
■ TKITT06._/BG3L.10		0.16m³ / 17kg / 1pcs
■ TKITT23._/BG3L		0.17m³ / 19.6kg / 1pcs
■ TKITT23._/BG3L.10		0.17m³ / 19.6kg / 1pcs

TKITT.BGA3L

H110 Table with technopolymer top, BG3L 3-spur metal-technopolymer co-injected table base, Ø 80mm anodized aluminum column.

Tavolo con piano in tecnopolimero H110, basamento BG3L a tre razze in metallo sovrastampato con tecnopolimero, colonna in alluminio anodizzato Ø 80mm.

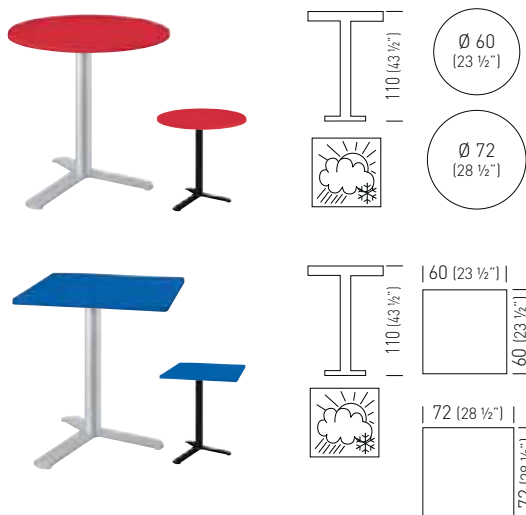

■ TKITT04._/BGA3L		0.18m³ / 15.8kg / 1pcs
■ TKITT04._/BGA3L.10		0.18m³ / 15.8kg / 1pcs
■ TKITT03._/BGA3L		0.20m³ / 16.5kg / 1pcs
■ TKITT03._/BGA3L.10		0.20m³ / 16.5kg / 1pcs
■ TKITT20._/BGA3L		0.18m³ / 16.6kg / 1pcs
■ TKITT20._/BGA3L.10		0.18m³ / 16.6kg / 1pcs
■ TKITT06._/BGA3L		0.20m³ / 17.8kg / 1pcs
■ TKITT06._/BGA3L.10		0.20m³ / 17.8kg / 1pcs

Top Color / Colore Piano

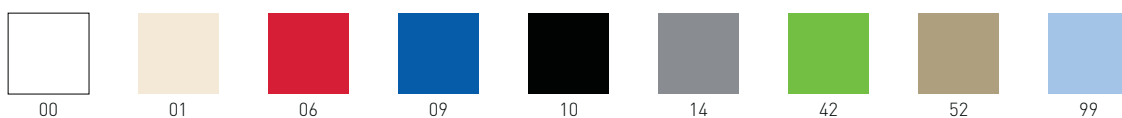

TKITT.BG4K

H75 Table with technopolymer top, BG4K 4-spur metal-technopolymer co-injected table base, Ø 80mm anodized aluminum column.

Tavolo con piano in tecnopolimero H75, basamento BG4K a quattro razze in metallo sovrastampato con tecnopolimero, colonna in alluminio anodizzato Ø 80mm.

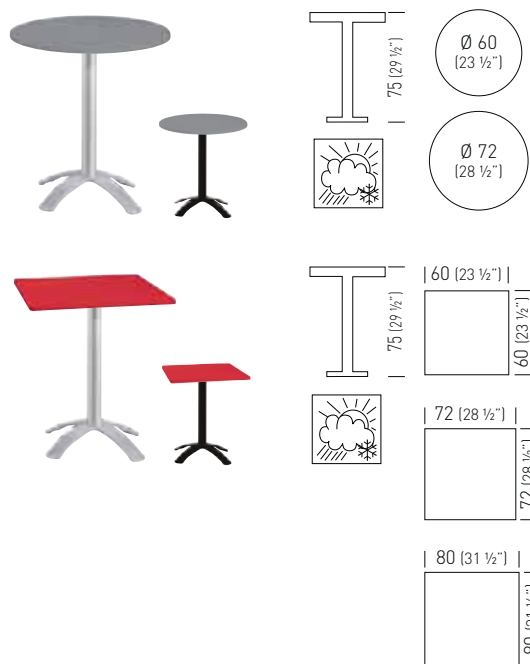

■ TKITT04._/BG4K  0.13m³ / 16.5kg / 1pcs
 ■ TKITT04._/BG4K.10  0.13m³ / 16.5kg / 1pcs

■ TKITT03._/BG4K  0.15m³ / 17.2kg / 1pcs
 ■ TKITT03._/BG4K.10  0.15m³ / 17.2kg / 1pcs

■ TKITT20._/BG4K  0.13m³ / 17.3kg / 1pcs
 ■ TKITT20._/BG4K.10  0.13m³ / 17.3kg / 1pcs

■ TKITT06._/BG4K  0.15m³ / 18.5kg / 1pcs
 ■ TKITT06._/BG4K.10  0.15m³ / 18.5kg / 1pcs

■ TKITT23._/BG4K  0.16m³ / 21.1kg / 1pcs
 ■ TKITT23._/BG4K.10  0.16m³ / 21.1kg / 1pcs

TKITT.BGA4K

H115 Table with technopolymer top, BG4K 4-spur metal-technopolymer co-injected table base, Ø 80mm anodized aluminum column.

Tavolo con piano in tecnopolimero H115, basamento BG4K a quattro razze in metallo sovrastampato con tecnopolimero, colonna in alluminio anodizzato Ø 80mm.

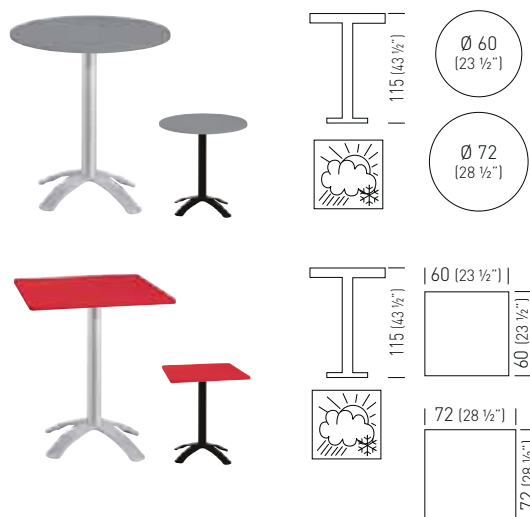

■ TKITT04._/BGA4K  0.17m³ / 17.3kg / 1pcs
 ■ TKITT04._/BGA4K.10  0.17m³ / 17.3kg / 1pcs

■ TKITT03._/BGA4K  0.19m³ / 18kg / 1pcs
 ■ TKITT03._/BGA4K.10  0.19m³ / 18kg / 1pcs

■ TKITT20._/BGA4K  0.17m³ / 18.1kg / 1pcs
 ■ TKITT20._/BGA4K.10  0.17m³ / 18.1kg / 1pcs

■ TKITT06._/BGA4K  0.19m³ / 19.3kg / 1pcs
 ■ TKITT06._/BGA4K.10  0.19m³ / 19.3kg / 1pcs

Top Color / Colore Piano

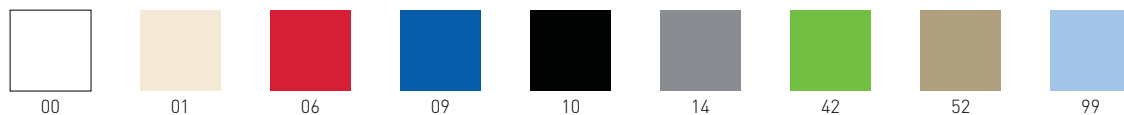

TKITT.BG4J

H73 Table with technopolymer top, BG4J 4-spur metal-technopolymer co-injected table base, 80x80mm anodized aluminum column.

Tavolo con piano in tecnopolimero H73, basamento BG4J a quattro razze in metallo sovrastampato con tecnopolimero, colonna in alluminio anodizzato 80x80mm.

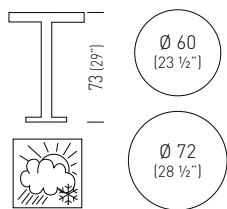

- TKITT04._/BG4J 0.16m³ / 16.8kg / 1pcs
- TKITT04._/BG4J.10 0.16m³ / 16.8kg / 1pcs

- TKITT03._/BG4J 0.18m³ / 17.5kg / 1pcs
- TKITT03._/BG4J.10 0.18m³ / 17.5kg / 1pcs

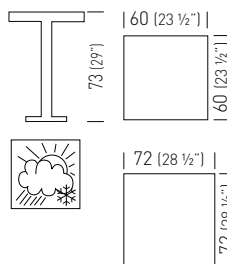

- TKITT20._/BG4J 0.16m³ / 17.6kg / 1pcs
- TKITT20._/BG4J.10 0.16m³ / 17.6kg / 1pcs

- TKITT06._/BG4J 0.18m³ / 18.8kg / 1pcs
- TKITT06._/BG4J.10 0.18m³ / 18.8kg / 1pcs

- TKITT23._/BG4J 0.19m³ / 21.4kg / 1pcs
- TKITT23._/BG4J.10 0.19m³ / 21.4kg / 1pcs

TKITT.BGPK

H75 folding table with technopolymer top, BG4J 4-spur metal-technopolymer co-injected base, Ø 80mm anodized aluminum column with flip-top mechanism.

Tavolo pieghevole con piano in tecnopolimero H75, basamento BGPK a quattro razze in metallo sovrastampato con tecnopolimero, colonna in alluminio anodizzato Ø 80mm.

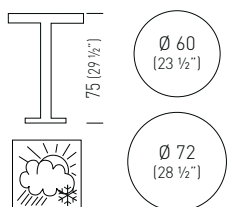

- TKITT04._/BGPK 0.13m³ / 17.5kg / 1pcs
- TKITT04._/BGPK.10 0.13m³ / 17.5kg / 1pcs

- TKITT03._/BGPK 0.15m³ / 18.2kg / 1pcs
- TKITT03._/BGPK.10 0.15m³ / 18.2kg / 1pcs

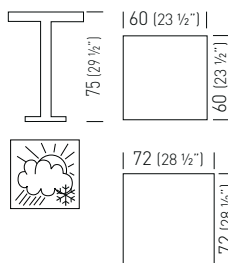

- TKITT20._/BGPK 0.13m³ / 18.3kg / 1pcs
- TKITT20._/BGPK.10 0.13m³ / 18.3kg / 1pcs

- TKITT06._/BGPK 0.15m³ / 19.5kg / 1pcs
- TKITT06._/BGPK.10 0.15m³ / 19.5kg / 1pcs

- TKITT23._/BGPK 0.16m³ / 22.1kg / 1pcs
- TKITT23._/BGPK.10 0.16m³ / 22.1kg / 1pcs

Top Color / Colore Piano

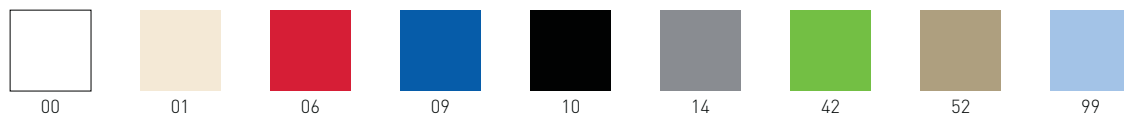

TKITT.BGPJ

H75 folding table with technopolymer top, BG4J 4-spur metal-technopolymer co-injected base, 80x80mm anodized aluminum column with flip-top mechanism.

Tavolo pieghevole con piano in tecnopolimero H75, basamento BGPJ a quattro razze in metallo sovrastampato con tecnopolimero, colonna in alluminio anodizzato 80x80mm.

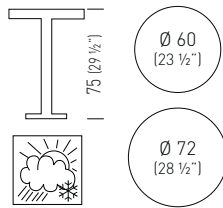

- TKITT04._/BGPJ 0.16m³ / 17.8kg / 1pcs
- TKITT04._/BGPJ.10 0.16m³ / 17.8kg / 1pcs

- TKITT03._/BGPJ 0.18m³ / 18.5kg / 1pcs
- TKITT03._/BGPJ.10 0.18m³ / 18.5kg / 1pcs

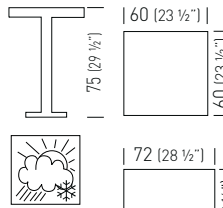

- TKITT20._/BGPJ 0.16m³ / 18.6kg / 1pcs
- TKITT20._/BGPJ.10 0.16m³ / 18.6kg / 1pcs

- TKITT06._/BGPJ 0.18m³ / 19.8kg / 1pcs
- TKITT06._/BGPJ.10 0.18m³ / 19.8kg / 1pcs

- TKITT23._/BGPJ 0.19m³ / 22.4kg / 1pcs
- TKITT23._/BGPJ.10 0.19m³ / 22.4kg / 1pcs

TKITT.BG4IP

Folding and stacking H75 table with technopolymer top, BG4IP 4-spur metal-technopolymer co-injected table base, Ø 80mm anodized aluminum column with flip-top mechanism and adjustable feet.

Tavolo pieghevole e accatastabile con piano in tecnopolimero H75, basamento BG4IP a quattro razze in metallo sovrastampato con tecnopolimero, colonna in alluminio anodizzato Ø 80mm e piedini regolabili.

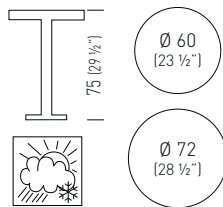

- TKITT04._/BG4IP 0.13m³ / 14kg / 1pcs
- TKITT04._/BG4IP.10 0.13m³ / 14kg / 1pcs

- TKITT03._/BG4IP 0.15m³ / 14.7kg / 1pcs
- TKITT03._/BG4IP.10 0.15m³ / 14.7kg / 1pcs

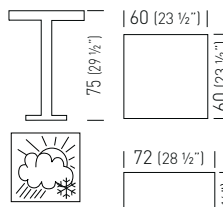

- TKITT20._/BG4IP 0.13m³ / 14.8kg / 1pcs
- TKITT20._/BG4IP.10 0.13m³ / 14.8kg / 1pcs

- TKITT06._/BG4IP 0.15m³ / 16kg / 1pcs
- TKITT06._/BG4IP.10 0.15m³ / 16kg / 1pcs

- TKITT23._/BG4IP 0.16m³ / 18.5kg / 1pcs
- TKITT23._/BG4IP.10 0.16m³ / 18.5kg / 1pcs

Top Color / Colore Piano

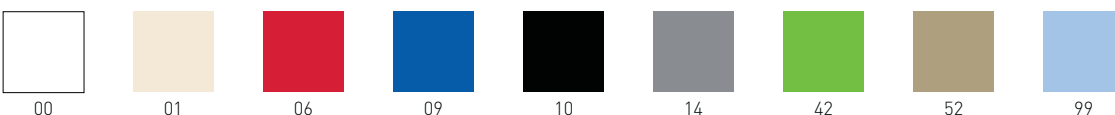

TKITT.BTK

H75 Table with technopolymer top, round BTK metal-technopolymer co-injected base, Ø 80mm anodized aluminum column.

Tavolo con piano in tecnopolimero H75, basamento BTK rotondo in metallo sovrastampato con tecnopolimero, colonna in alluminio anodizzato Ø 80mm.

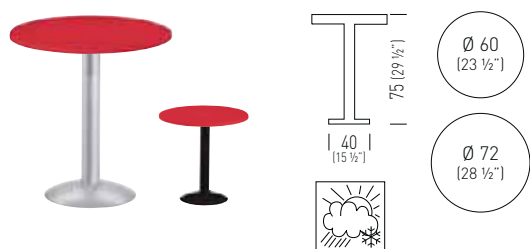

■ TKITT04._/BTK 0.16m³ / 13.8kg / 1pcs
 ■ TKITT04._/BTK.10 0.16m³ / 13.8kg / 1pcs

■ TKITT03._/BTK 0.18m³ / 14.5kg / 1pcs
 ■ TKITT03._/BTK.10 0.18m³ / 14.5kg / 1pcs

TKITT.BTAK

H110 Table with technopolymer top, round BTAK metal-technopolymer co-injected base, Ø 80mm anodized aluminum column.

Tavolo con piano in tecnopolimero H110, basamento BTAK rotondo in metallo sovrastampato con tecnopolimero, colonna in alluminio anodizzato Ø 80mm.

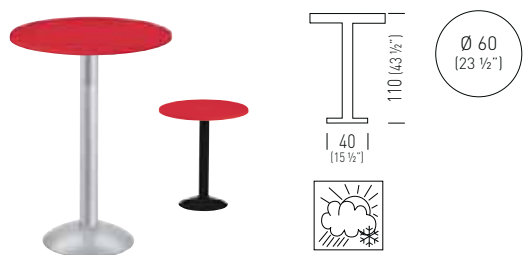

■ TKITT04._/BTAK 0.17m³ / 14.8kg / 1pcs
 ■ TKITT04._/BTAK.10 0.17m³ / 14.8kg / 1pcs

Top Color / Colore Piano

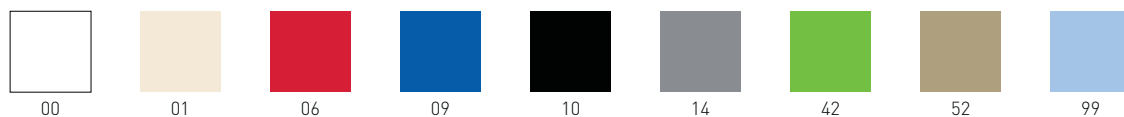

TKITT.BTK54

H75 Table with technopolymer top, round BTK54 metal-technopolymer co-injected table base, Ø 80mm anodized aluminum column.

Tavolo con piano in tecnopolimero H75, basamento BTK54 rotondo in metallo sovrastampato con tecnopolimero, colonna in alluminio anodizzato Ø 80mm.

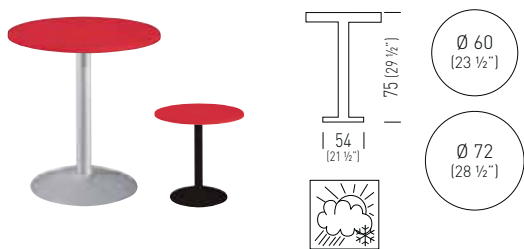

■ TKITT04._/BTK54		0.16m³ / 16.3kg / 1pcs
■ TKITT04._/BTK54.10		0.16m³ / 16.3kg / 1pcs
■ TKITT03._/BTK54		0.18m³ / 17kg / 1pcs
■ TKITT03._/BTK54.10		0.18m³ / 17kg / 1pcs

TKITT.BTAK54

H110 Table with technopolymer top, round BTK54 metal-technopolymer co-injected table base, Ø 80mm anodized aluminum column.

Tavolo con piano in tecnopolimero H110, basamento BTAK54 rotondo in metallo sovrastampato con tecnopolimero, colonna in alluminio anodizzato Ø 80mm.

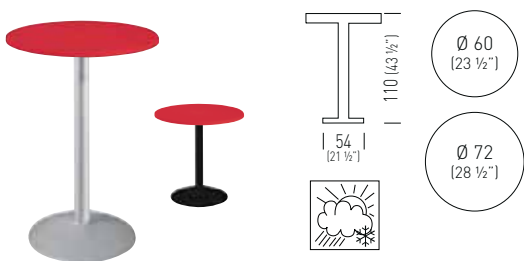

■ TKITT04._/BTAK54		0.17m³ / 17.3kg / 1pcs
■ TKITT04._/BTAK54.10		0.17m³ / 17.3kg / 1pcs
■ TKITT03._/BTAK54		0.19m³ / 18kg / 1pcs
■ TKITT03._/BTAK54.10		0.19m³ / 18kg / 1pcs

Top Color / Colore Piano

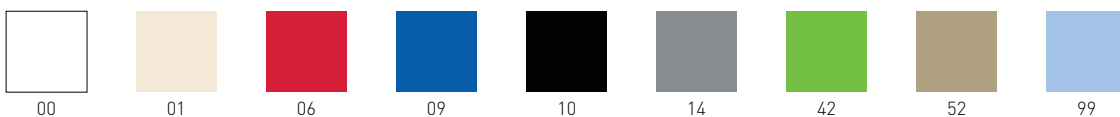

TKITT.DPBT54

H110 double table with technopolymer tops, round DPBT54 metal-technopolymer co-injected base, Ø 80mm anodized aluminum column.

Tavolo con doppio piano in tecnopolimero H110, basamento DPBT54 rotondo in metallo sovrastampato con tecnopolimero, colonna in alluminio anodizzato Ø 80mm.

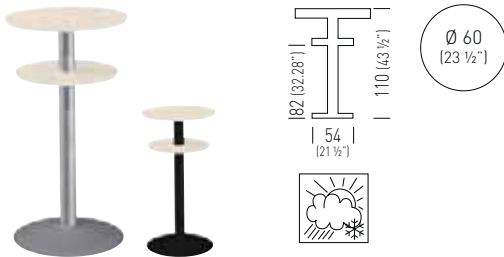

- TKITT08._/DPBT54 0.15m³ / 16.5kg / 1pcs
- TKITT08._/DPBT54.10 0.15m³ / 16.5kg / 1pcs

TKITT.BRK

H75 Table with technopolymer top, round BRK metal-technopolymer co-injected base, Ø 80mm anodized aluminum column.

Tavolo con piano in tecnopolimero H75, basamento BRK rotondo in metallo sovrastampato con tecnopolimero, colonna in alluminio anodizzato Ø 80mm.

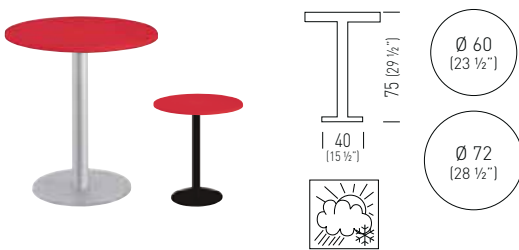

- TKITT04._/BRK 0.13m³ / 14.3kg / 1pcs
- TKITT04._/BRK.10 0.13m³ / 14.3kg / 1pcs
- TKITT03._/BRK 0.15m³ / 15kg / 1pcs
- TKITT03._/BRK.10 0.15m³ / 15kg / 1pcs

Top Color / Colore Piano

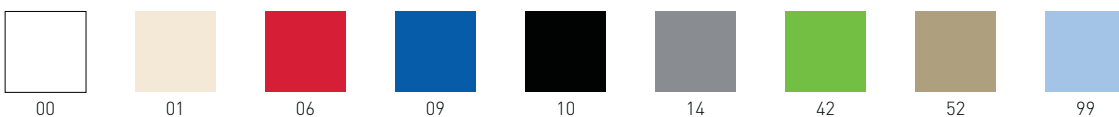

TKITT.BQJ

H74 Table with technopolymer top, square BQJ metal-technopolymer co-injected table base, 80x80mm anodized aluminum column.

Tavolo con piano in tecnopolimero H74, basamento BQJ quadrato in metallo sovrastampato con tecnopolimero, colonna in alluminio anodizzato 80x80mm.

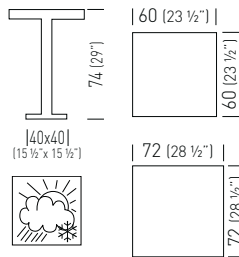

■ TKITT20._/BQJ	0.13m³ / 17.1kg / 1pcs
■ TKITT20._/BQJ.10	0.13m³ / 17.1kg / 1pcs
■ TKITT06._/BQJ	0.15m³ / 18.3kg / 1pcs
■ TKITT06._/BQJ.10	0.15m³ / 18.3kg / 1pcs

TKITT.BQAJ

H103 Table with technopolymer top, square BQJ metal-technopolymer co-injected table base, 80x80mm anodized aluminum column.

Tavolo con piano in tecnopolimero H103, basamento BQJ quadrato in metallo sovrastampato con tecnopolimero, colonna in alluminio anodizzato 80x80mm.

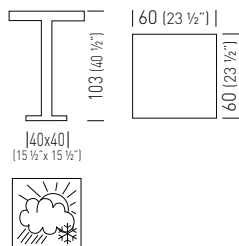

■ TKITT20._/BQAJ	0.14m³ / 17.6kg / 1pcs
■ TKITT20._/BQAJ.10	0.14m³ / 17.6kg / 1pcs

Top Color / Colore Piano

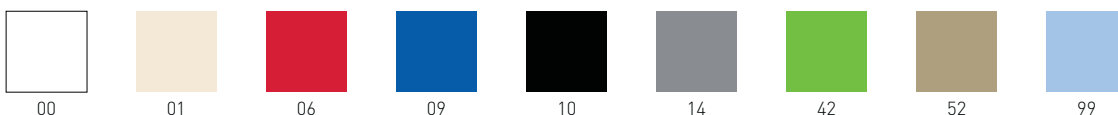

TIMPT.STAKY

Stackable table collection, suitable for outdoor use.
Techno polymer tops and anodized aluminum frames.

Collezione di tavoli impilabili, adatti all'uso esterno.
I tavoli sono realizzati con piani in tecnopolimero e struttura in alluminio anodizzato.

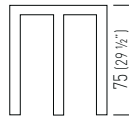

TIMPT04._/H75

0.08m³ / 7.1kg / 1pcs



TIMPT03._/H75

0.08m³ / 7.3kg / 1pcs

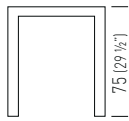

TIMPT20._/H75

0.05m³ / 7.6kg / 1pcs



TIMPT23._/H75

0.09m³ / 8kg / 1pcs

Top Color / Colore Piano



00



01



06



09



10



14



42



52



99

TCONT.STEADY

Counterbalanced tables collection, suitable for outdoor use.
Techno polymer tops and anodized aluminum frames.

Collezione di tavoli a contrappesi, adatti all'uso esterno.
I tavoli sono realizzati con piani in tecnopolimero e struttura in alluminio anodizzato.

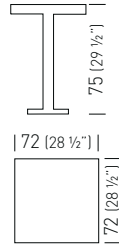

TCONT06._/H75

 0.08m³ / 12.8kg / 1pcs

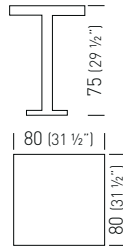

TCONT23._/H75

 0.10m³ / 13kg / 1pcs

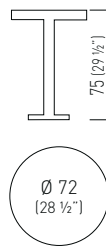

TCONT03._/H75

 0.08m³ / 12.6kg / 1pcs

Top Color / Colore Piano



00



01



06



09



10



14



42



52



99